

High Precision Flanged Torque Sensor

Rotary, non-contact

MODEL 8670 **NEW**



Highlights

- Measuring ranges from 0 ... 100 N·m up to 0 ... 5000 N·m
- Low non-linearity $\leq 0.05\%$ F.S.
- Flange connection with DIN hole pattern
- Space-saving extremely short design
- Analog output: $\pm 10\text{ V}$, $\pm 5\text{ V}$ (up to 6 kHz, 16 bit)
- Adjustable frequency output (24 bit)
- CAN 2.0 (11 bit, up to 2 kHz)
- User-defined alarm outputs
- Sensor configurable via Ethernet

Options

- Dual range version with two genuine measuring ranges
- Speed/angle measurement

Applications

- Test bench construction
- Quality monitoring for electric motors and gearboxes
- Research and development
- Mechanical and plant engineering

Product description

The type 8670 rotary flanged torque sensor consists of the sensor (rotor), receiver (stator) and evaluation electronics. A 10-meter connecting cable from the stator to the evaluation electronics is included.

Torque is measured via the torsion of the rotor using strain gages. Transmission is wireless and fully contactless. As there is no bearing, the sensor is maintenance free. Signals are digitized directly on the shaft and made available via the evaluation electronics as a voltage signal, frequency or CAN signal. The direction of rotation is indicated by the polarity of the output voltage: clockwise produces a positive output voltage, anticlockwise negative.

The web interface lets users define the desired output signal, check measured values and the status, and set alarm outputs. In addition, an overload channel is available. This transmits measured values of up to 300 % of the rated torque. The rotor temperature is measured and used for compensation. The temperature is displayed in the web interface and is available as a measured value via CAN.

Thanks to its ringless design and extremely compact dimensions, the sensor is easy to integrate. The flange dimensions conform to the DIN standard and are compatible with existing systems.

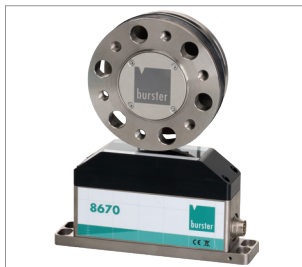

Rotor with stator



Evaluation electronics

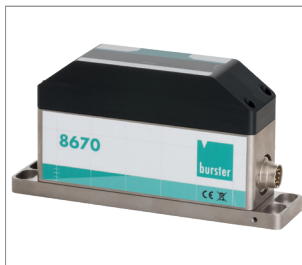

Stator

Technical data

8670	-	5100	5200	5500	6001	6002	6003	6004	6005
Measuring range calibrated in N·m from 0 ...	[N·m]	100	200	500	1000	2000	3000	4000	5000
Accuracy									
Relative non-linearity, including hysteresis		0.05 % F.S.							
Characteristic value tolerance		0.1 % F.S.							
Temperature effect on zero		±0.03 % F.S./10 K							
Temperature effect on characteristic value		±0.03 % F.S./10 K							
Electrical values									
Supply voltage		24 V DC ±1 V							
DC power consumption		< 24 W							
Output signals (configurable)		Frequency output (RS-422): 10±5 kHz, 60±20 kHz, 60±30 kHz, 240±120 kHz Analog output: 0 - 5 V, 0 - 10 V, ±5 V, ±10 V CAN (2B, 2 kHz)							
Ambient conditions									
Rated temperature range rotor/stator		+10 °C ... +80 °C							
Operating temperature range rotor/stator		-20 °C ... +85 °C							
Mechanical values									
Max. operating torque		300 % of rated torque							
Breaking torque		600 % of rated torque							
Max. axial load	[kN]	13	17	26	46	57	83	89	
Max. radial load	[kN]	3	4	7	11	15	20	23	
Max. speed	[min ⁻¹]	21000		20000	16000		15000		
Spring constant	[kN.m/rad]	152	266	647	1461	1988	3317	3894	
Moment of inertia rotor	[kg·m ²]	0.0017		0.0034	0.0085		0.0188	0.0189	
Installation									
Radial distance rotor/stator	[mm]	3 (+1/-2)							
Axial distance rotor/stator	[mm]	7 (±1)							
Miscellaneous									
Weight rotor	[kg]	1.2	1.3	1.7	2.9		4.4	4.5	
Weight stator	[kg]	0.6							

Dimensional drawing

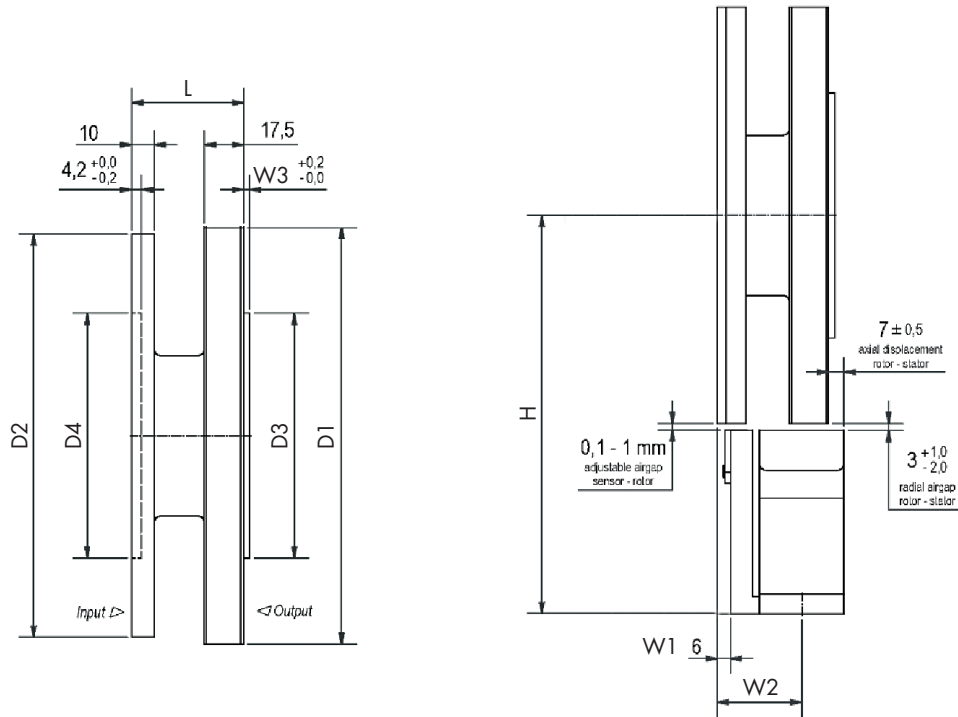

8670	-	5100	5200	5500	6001	6002	6003	6004	6005
Measuring range from 0 ...		100	200	500	1000	2000	3000	4000	5000
Geometry									
D1	[mm]		107		128		158		181
D2	[mm]		101		122		152		187
D3	[mm]		57 g5		75 g5		90 g5		110 g5
D4	[mm]		57 H6		75 H6		90 h6		110 H6
H	[mm]		139		149.5		164.5		179
W1	[mm]		14		17		18		19
W2	[mm]		33		55		56		38
W3	[mm]		2				2.5		2.8
Hole circle Ø	[mm]		84		101.5		130		155.5
L	[mm]		45			49			50
Balance quality grades ISO 1940			2.5						

For detailed dimensional specifications, please refer to the CAD data and separate technical drawings of the sensor on our website www.burster.de

Options

Dual range version

The sensor with two measuring ranges has the same dimensions as the standard version but features two genuine measuring ranges that are calibrated separately. The two measurement signals are output in parallel, as a frequency (RS-422), analog signal, and via CAN. The available ratio is 1:5 of the rated torque; for the 200 Nm measuring range a 1:4 ratio is available.

Speed and angle measurement

The speed is measured via an additional magnetic ring on the rotor. This is sensed by electronics on the stator, providing two 90° phase-shifted signals.

The number of pulses per revolution depends on the number of increments on the speed ring.

The speed signal is transmitted as a frequency (RS-422) or if required also as an analog signal and via CAN. The analog signal can be configured using the web interface.

Measuring ranges 100 Nm to 500 Nm:	680 pulses, max. speed ≤ 21000 min ⁻¹
Measuring range 1000 Nm:	808 pulses, max. speed ≤ 20000 min ⁻¹
Measuring ranges 2000 Nm and 3000 Nm:	1000 pulses, max. speed ≤ 16000 min ⁻¹
Measuring ranges 4000 Nm and 5000 Nm:	1176 pulses, max. speed ≤ 15000 min ⁻¹

Accessories

Order code	
9900-V680	Mating connector for X10 (included with device)
9900-V681	Mating connector for X11 (included with device)
9900-K501	Connecting cable for X10: Power supply / frequency output, one end open, length 5 meters
9900-K502	Connecting cable for X11: Analog / CAN / alarm / input, one end open, length 5 meters
9900-K605	Connecting cable stator to evaluation unit, length 5 meters
9900-K610	Connecting cable stator to evaluation unit, length 10 meters (included with device)
9900-K615	Connecting cable stator to evaluation unit, length 15 meters
9900-K620	Connecting cable stator to evaluation unit, length 20 meters
9900-K625	Connecting cable stator to evaluation unit, length 25 meters
9900-K630	Connecting cable stator to evaluation unit, length 30 meters

Calibration

Test and calibration log	
Is supplied with the sensor	With details of the zero point, full-scale output and shunt calibration.
Standard factory calibration certificate for torque sensors or measurement chains (WKS)	
Optionally available	Calibration of the clockwise and/or anticlockwise torque in steps of 20 % of the measuring range, rising and falling.
Special factory calibration certificate for torque sensors or measurement chains (WKS)	
On request	We are happy to calibrate sensors and measurement chains to the customer's specification.
Calibration certificate with accreditation symbol for 8670 torque sensor	
Optionally available	Calibration is based on the accreditation of calibration laboratory D-K-15141-01-00, for the scope of parameters listed in the annex to the accreditation certificate. Traceability to national standards and wide international recognition is therefore assured (DAkkS is a signatory to the EA, ILAC and IAF Multilateral Recognition Arrangements). Calibration services not covered by the D-K-15141 calibration laboratory may be carried out by an external laboratory that has DAkkS accreditation for the required scope of services.

Order code

Measuring range		Code			
0 ... 100 N·m		5	1	0	0
0 ... 200 N·m		5	2	0	0
0 ... 500 N·m		5	5	0	0
0 ... 1000 N·m		6	0	0	1
0 ... 2000 N·m		6	0	0	2
0 ... 3000 N·m		6	0	0	3
0 ... 4000 N·m		6	0	0	4
0 ... 5000 N·m		6	0	0	5

											Standard				
											0	0	0	3	0
8	6	7	0	-	X	X	X	X	-	V			0	3	0
<ul style="list-style-type: none"> ■ Dual range version, ratio 1:5 ■ Dual range version, ratio 1:4 															
<ul style="list-style-type: none"> ■ 680 pulses, measuring range from 100 Nm to 500 Nm ■ 808 pulses, measuring range 1000 Nm ■ 1000 pulses, measuring range 2000 Nm and 3000 Nm ■ 1176 pulses, measuring range 4000 Nm and 5000 Nm 															