

Operation Manual for Torque Sensors

For below and similar Types



86-2500 / 86-2600

Imprint

Valid for...	Torque Sensor Type 86-2500 / 86-2600
Reprint-Interdiction	Reprint, even in extracts, only with written authorization.
Modification	Technical changes reserved.

References in this Text

1.6 Warning Notes; Page 5



Attention must be paid to the accident prevention regulations of the trade associations. Coverings and casings are necessary before operating the sensor. This is also valid for commissioning, maintenance and trouble shooting.

Duties of the coverings and casings are:

- ⇒ Protection from detaching parts
- ⇒ Protection from contusion and shear
- ⇒ Prevention from reaching rotating parts
- ⇒ Prevention from being tangled up and/or getting caught by parts

Coverings may

- ⇒ Not grind
- ⇒ Not rotate

Coverings are also necessary outside of operating and motion travel areas of persons. These demands can be modified if other sufficient safety devices are available. During operation, the safety precautions must be operative. By vibrations, damages can occur at the device.

4 Mechanical Assembly; Page 8



Caution: During the assembly inadmissibly large forces may not act on the sensor or the couplings. At small torques (< 20 N·m) connect the sensor electrically during the assembly and observe the signal, the measurement signal may not exceed the limit values.



During the assembly the sensor must be supported to protect it from falling down.



At torques < 20 N·m always start the assembly at the **low torque resistance side**



Admissible assembly offset from rotor to stator: axial ± 1 mm.

4.1.3 Alignment of the Measurement Arrangement; Page 9



For further references see coupling manual of the coupling producer and/or the data sheet.

4.2 Assembly Possibility Stator; Page 9



The thread depth must be considered (possible damage of the stator electronics).
See data sheet.

4.5 Installation Instruction; Page 10



Treat the sensor with utmost care.



Do not apply bending moment or torque to the sensor.



Store or transport the sensor with fixing half shells only.



Only use single-jointed couplings on both sides.

6.1 Engaging; Page 15



Warming-up period of the torque sensor is approx. 5 min.

6.4.2 Natural Resonances; Page 15



An operation of the device in natural resonance can lead to permanent damages.

Contents

1	Read First	5
1.1	Safety and Caution Symbols	5
1.2	Intended Use	5
1.3	Dangers	5
1.3.1	Neglecting of Safety Notes	5
1.3.2	Remaining Dangers	5
1.4	Reconstructions and Modifications	5
1.5	Personnel	5
1.6	Warning Notes	5
2	Term Definitions	6
2.1	Terms	6
2.2	Definition of the Pictograms on the Torque Sensor	6
3	Product Description	6
3.1	Mechanical Setup	6
3.2	Electrical Setup	7
3.2.1	Sensors with Analog Output	7
3.2.2	Sensors with Interface RS485	7
3.2.3	The Serial Communication	7
4	Mechanical Assembly	8
4.1	Couplings	8
4.1.1	Examples for Single-Jointed Couplings	8
4.1.2	Misalignment Possibilities of Single-Jointed Couplings	8
4.1.3	Alignment of the Measurement Arrangement	9
4.2	Assembly Possibility Stator	9
4.3	Fixing Half Shells	9
4.3.1	Nominal torque up to 10 N·m	9
4.3.2	Nominal Torque 20 N·m up to 150 N·m	10
4.4	Basic Assembly	10
4.5	Installation Instruction	10
4.5.1	Installation Steps	11
5	Electrical Connection	13
5.1	Pin Connection	13
5.2	Cable	14
5.3	Shielding Connection	14
5.4	Running of Measuring Cables	14
5.5	Electrical Calibration	14
5.5.1	Switch-On of Calibration Control at Analog Output	14
5.5.2	Calibration Control at RS485	14
5.6	Speed Sensor (Option)	14
6	Measuring	15
6.1	Engaging	15
6.2	Direction of Torque	15
6.3	Static / Quasi-Static Torques	15
6.4	Dynamic Torques	15
6.4.1	General	15
6.4.2	Natural Resonances	15
6.5	Speed Limits	15
6.6	Disturbance Variables	15
7	Maintenance	16
7.1	Maintenance Schedule	16
7.2	Trouble Shooting	16
8	Decommission	17
9	Transportation and Storage	17
9.1	Transportation	17
9.2	Storage	17
10	Disposal	17
11	Calibration	17



11.1	Proprietary Calibration.....	17
11.2	DKD-Calibration	17
11.3	Re-Calibration	17
12	Data Sheet	18

1 Read First

1.1 Safety and Caution Symbols



Caution:

Injury Risk for Persons
Damage of the Device is possible

Note:

Important points to be considered

1.2 Intended Use

Torque sensors are intended for the measurement of torques. This measurand is further suitable for control tasks. The valid safety regulations should be absolutely respected. The torque sensors are not safety components in the sense of the intended use. The sensors need to be transported and stored appropriately. The assembly, commissioning and disassembling must take place professionally.

1.3 Dangers

The torque sensor is fail-safe and corresponds to the state of technology.

1.3.1 Neglecting of Safety Notes

At inappropriate use, remaining dangers can emerge (e.g. by untrained personnel). The operation manual must be read and understood by each person entrusted with the assembly, maintenance, repair, operation and disassembly of the torque sensor.

1.3.2 Remaining Dangers

The plant designer, the supplier, as well as the operator must plan, realize and take responsibility for safety-related interests for the sensor. Remaining dangers must be minimized. Remaining dangers of the torque measurement technique must be pointed out.

Human mistakes must be considered. The construction of the plant must be suitable for the avoidance of dangers. A danger-analysis for the plant must be carried out.

1.4 Reconstructions and Modifications

Each modification of the sensors without our written approval excludes liability on our part.

1.5 Personnel

The installation, assembly, commissioning, operation and the disassembly must be carried out by qualified personnel only. The personnel must have the knowledge and make use of the legal regulations and safety instructions.

1.6 Warning Notes



Attention must be paid to the accident prevention regulations of the trade associations.

Coverings and casings are necessary before operating the sensor. This is also valid for commissioning, maintenance and trouble shooting.

Duties of the coverings and casings are:

- ⇒ Protection from detaching parts
- ⇒ Protection from contusion and shear
- ⇒ Prevention from reaching rotating parts
- ⇒ Prevention from being tangled up and/or getting caught by parts

Coverings may

- ⇒ Not grind
- ⇒ Not rotate

Coverings are also necessary outside of operating and motion travel areas of persons.

These demands can be modified if other sufficient safety devices are available. During operation, the safety precautions must be operative. By vibrations, damages can occur at the device.

2 Term Definitions

2.1 Terms

Measuring Side:

Mechanical connection of the torque sensor in which the torque to be measured is applied. Usually this side has the smallest moment of inertia.

Drive Side:

Mechanical connection of the torque sensor on the opposite side of the measuring side, usually with the largest moment of inertia. At static torque sensors the housing is fastened on this side.

Low Torque Resistance Side:

The shaft of the arrangement (drive, load) which can be turned considerably smaller with torque than the nominal torque of the torque sensor $M \ll M_{nenn}$.

2.2 Definition of the Pictograms on the Torque Sensor

The measuring side of the torque sensor is designated as follows:

Measuring side:

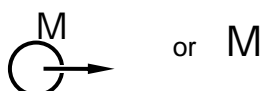

More information can be found on the data sheet if needed.

3 Product Description

The sensor measures static and dynamic torques. The mounting position of the torque sensor is horizontally.

Caution: it is to be differentiated between measuring side and drive side, see data sheet of the sensor: <http://www.burster.it>

3.1 Mechanical Setup

The sensor consists of a stationary part, the stator and a rotary part, the rotor.

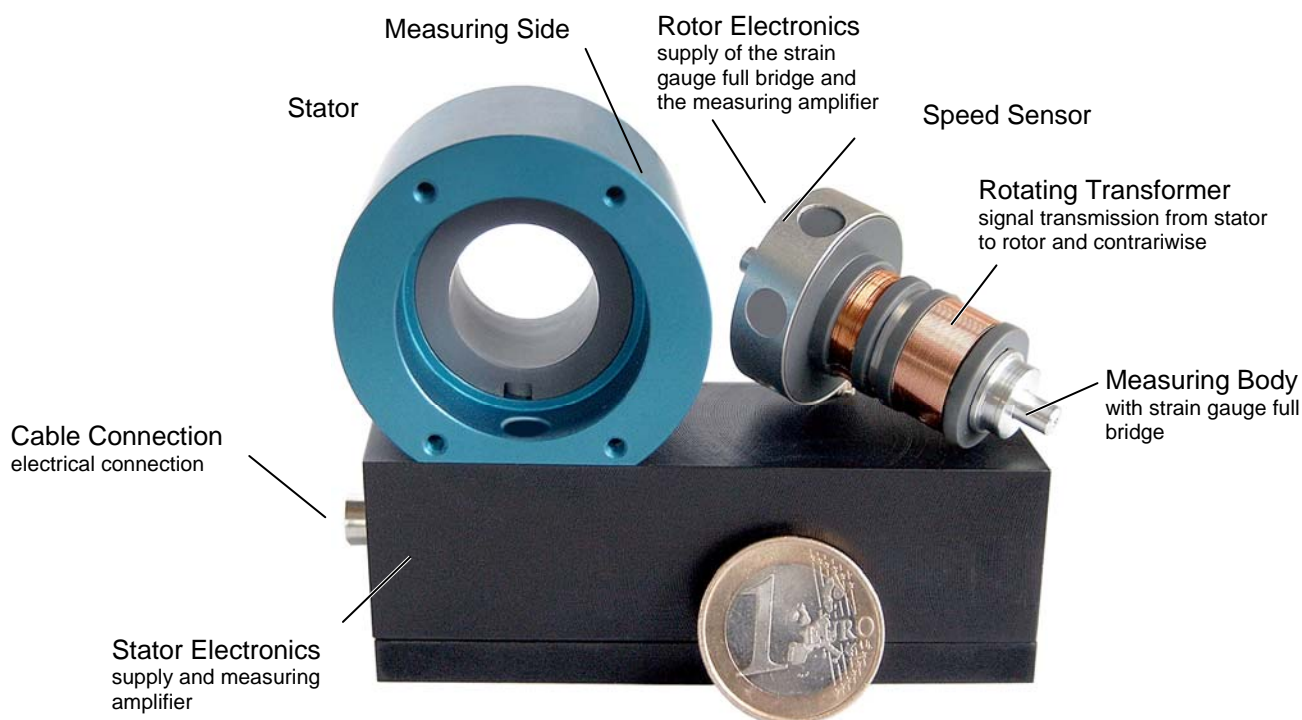

3.2 Electrical Setup

The supply of the rotor electronics occurs by an alternating voltage, generated in the stator, which transfers to the rotor through a rotating transformer. There, it is rectified and stabilized. With this supply, the strain gauge bridge is fed.

For the electrical calibration control of the sensor, a control signal is up-modulated to the supply by the μ -processor in the stator and transferred to the rotor. There, it is filtered and evaluated by the μ PC, which also activates the internal switch for the detuning of the strain gauge bridge.

The measuring signal of the strain gauge bridge is conditioned in an amplifier and then converted into a digital signal, which will be transferred to the stator by another rotating transformer. Compared to the analog signal, the measuring signal in digital form is much more disturbance-free. The remaining distance of the measuring signal within the sensor occurs in digital form, completely. Thus, the measuring system achieves a high reliability of operation.

This signal is further conditioned in the stator, comes into a μ -processor, then - depending upon sensor type - it is converted to a voltage signal, digital signal or to current and will then reach the output of the sensor and can be directly measured at the connector.

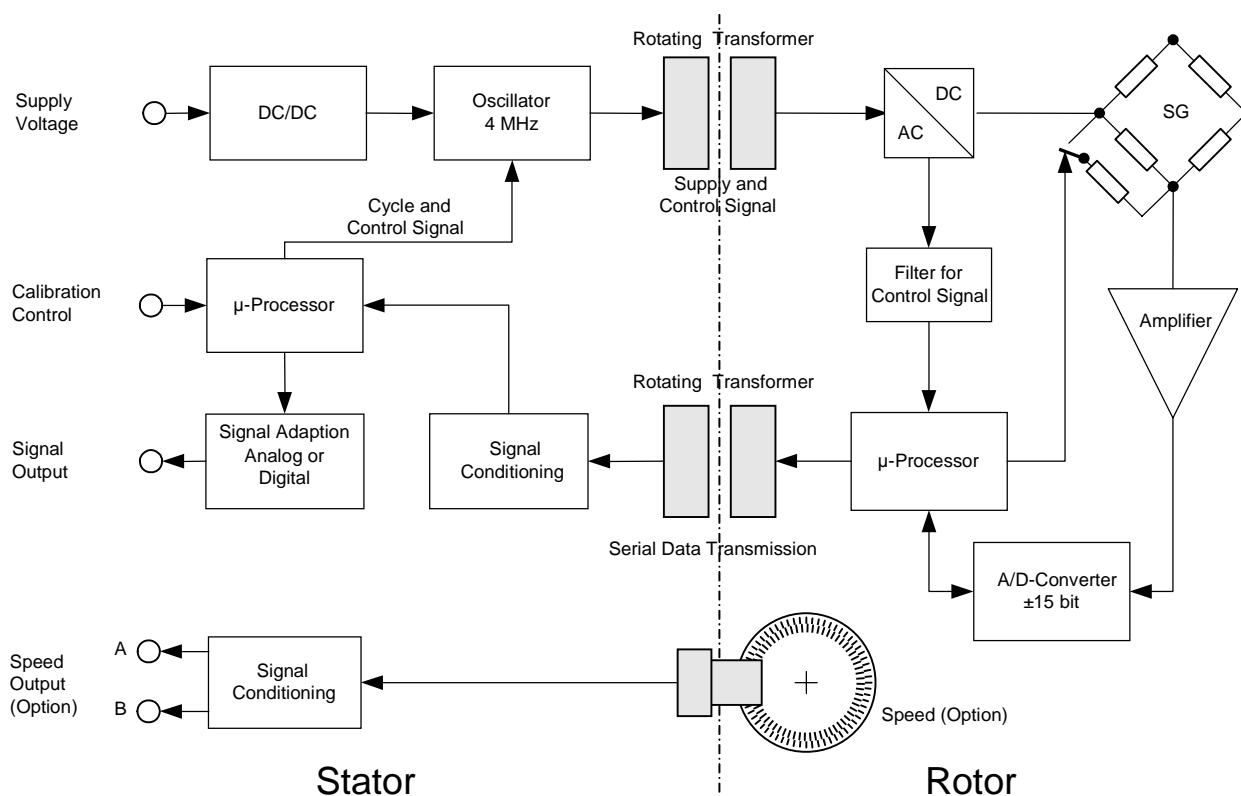

3.2.1 Sensors with Analog Output

At this output, the digital signal is converted into DC voltage of 0 V ± 5 V, proportionally to the torque and is available at the connector output.

3.2.2 Sensors with Interface RS485

The torque sensor has a digital interface RS485 for the signal output and automatic sensor identification.

The protocol enables high dynamics.

See separate manual for further information.

3.2.3 The Serial Communication

See Protocol, Document Number 090110.

4 Mechanical Assembly



Caution: During the assembly inadmissibly large forces may not act on the sensor or the couplings. At small torques (< 20 N·m) connect the sensor electrically during the assembly and observe the signal, the measurement signal may not exceed the limit values.



During the assembly the sensor must be supported to protect it from falling down.



At torques < 20 N·m always start the assembly at the **low torque resistance side**



Admissible assembly offset from rotor to stator: axial ± 1 mm.

4.1 Couplings

4.1.1 Examples for Single-Jointed Couplings

For this torque sensor we recommend the couplings intended by burster which must be able to balance an axial, radial or angular offset of the shafts and not allow large forces to act on the sensor.



4.1.2 Misalignment Possibilities of Single-Jointed Couplings

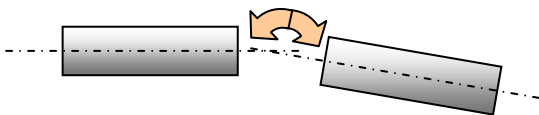

Angular Misalignments

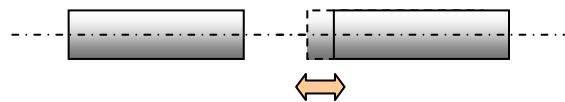

Axial Misalignments

Note: Radial misalignments are only possible in the combination of single-jointed coupling - torque sensor (as adapter) - single-jointed coupling.

Thus, with both single-jointed couplings the torque sensor forms a double-jointed coupling.

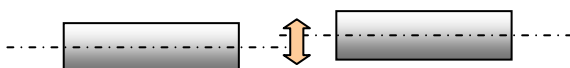
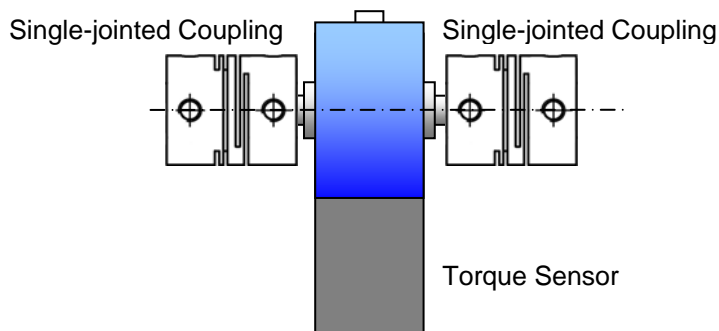

Radial Misalignments

4.1.3 Alignment of the Measurement Arrangement

Precisely alignment of the couplings reduces the reaction forces and increases the durability of the couplings. Disturbance variables are minimized as well.

Due to the multitude of applications, an alignment of the coupling with a straight edge in two levels, vertical to each other, is sufficient.

However, in drives with high speed an alignment of the coupling (shaft ends) with a dial gauge or a laser is recommended.

Further points to consider

- The axis height of the torque sensor (data sheet) must be considered as well.
- An air gap between rotor and stator must be existent. The rotor may not touch the stator in any operating state.
- Axial position of the rotor to the stator, see data sheet.



For further details see the manual for couplings and/or the data sheet.

4.2 Assembly Possibility Stator

Thread holes for fixation are available at the stator housing.



The thread depth must be considered (possible damage of the stator electronics). See data sheet.

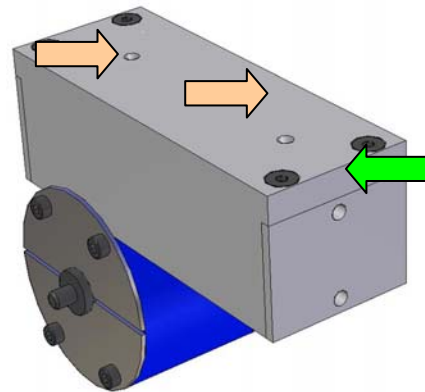

4.3 Fixing Half Shells

4.3.1 Nominal torque up to 10 N·m

Since the shaft has no bearings, the sensor is delivered with fixing half shells. The fixing half shells are used for the positioning and the fixation of the shaft in the stator. At mounted half shells the shaft can be turned and it can also be damaged by forces.

Remove the fixing half shells as described hereafter in chapter **Installation Instruction**.

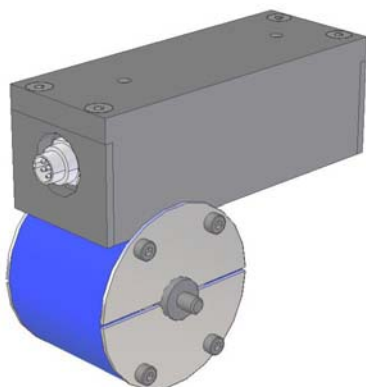

Fixing half shells mounted

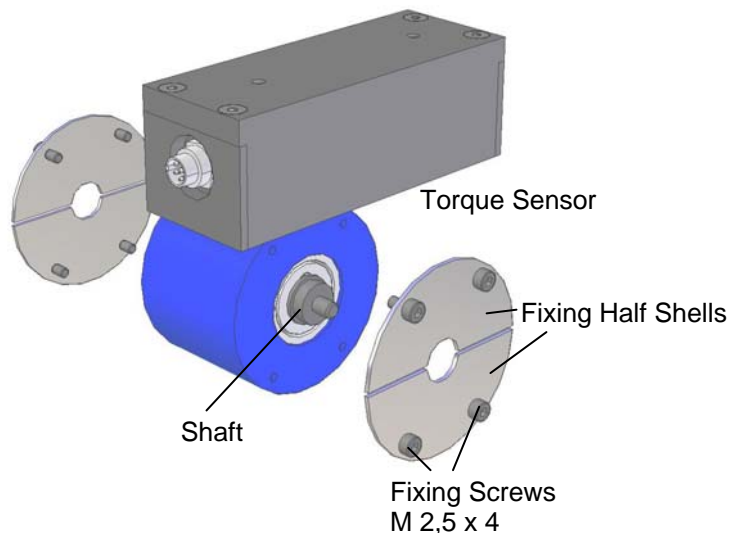

Remove the fixing half shells after the sensor assembly

4.3.2 Nominal Torque 20 N·m up to 150 N·m

Since the shaft has no bearings, the sensor is delivered with fixing half shells. The fixing half shells are used for the positioning and the fixation of the shaft in the stator. At mounted half shells the shaft can still be turned.

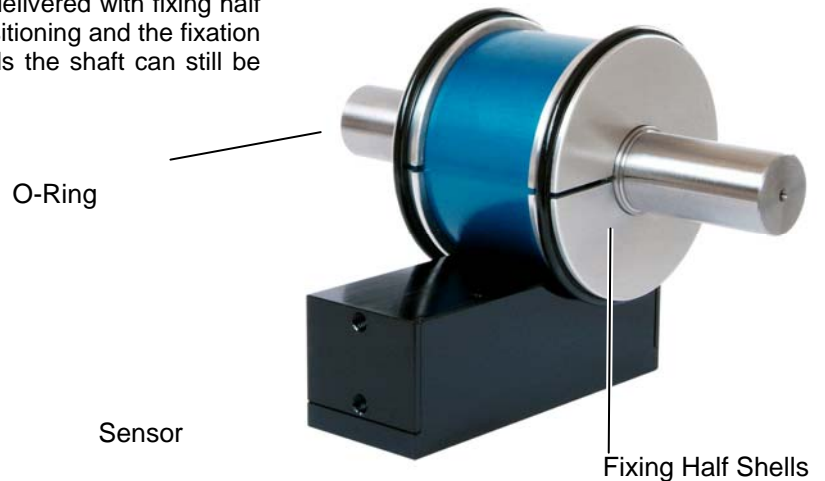

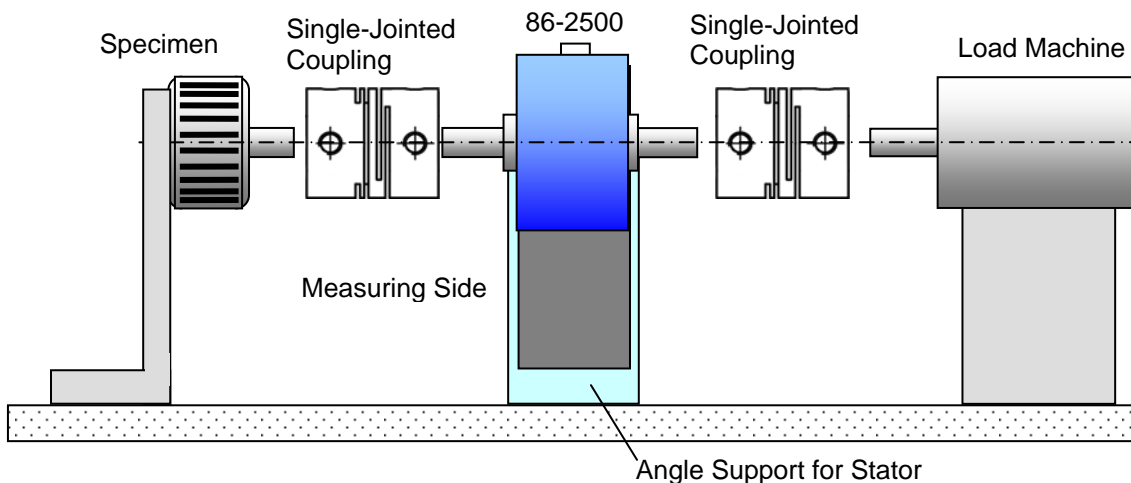

4.4 Basic Assembly



4.5 Installation Instruction

Measuring Range: 0,005 N·m up to 150 N·m

-  Treat the sensor with utmost care.
Do not apply bending moment or torque to the sensor
-  Store or transport the sensor with fixing half shells only.
-  Only use single-jointed couplings on both sides.

The two coupling connections at customers side must be aligned exactly to each other. With the use of BSD THOMAS-Miniature Couplings Type 966 the axial tension may not exceed the maximum of 0,2 mm and the angular offset may not exceed the maximum of 0,5°.

First assure that the couplings can be easily shifted on the shaft ends.

The fixing half shells (shaft to housing) must stay in mounted condition at the beginning of the assembly.

The housing may be positioned firmly only after the fixing half shells have been removed.

4.5.1 Installation Steps

1. Testing and alignment of the coupling connections on customer side.
2. Fasten both single-jointed couplings to the shaft ends of the torque sensors without loading the torque shaft with torque or bending (counterhold at coupling) The sensor housing may not be turned during the assembly.

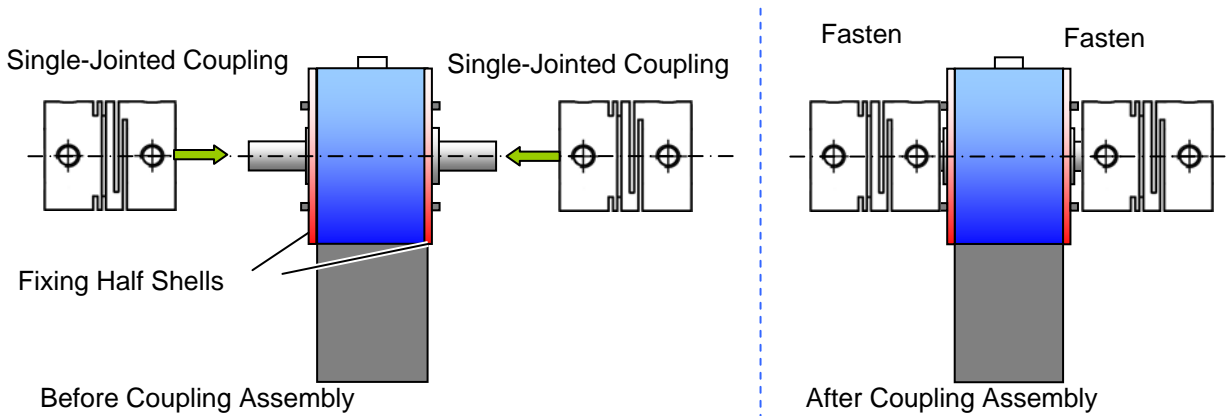

3. Shift the first coupling (with sensor) on the shaft string on customer side. Support the housing at the same time, so that the shaft is not exposed to bending moment and/or torque.

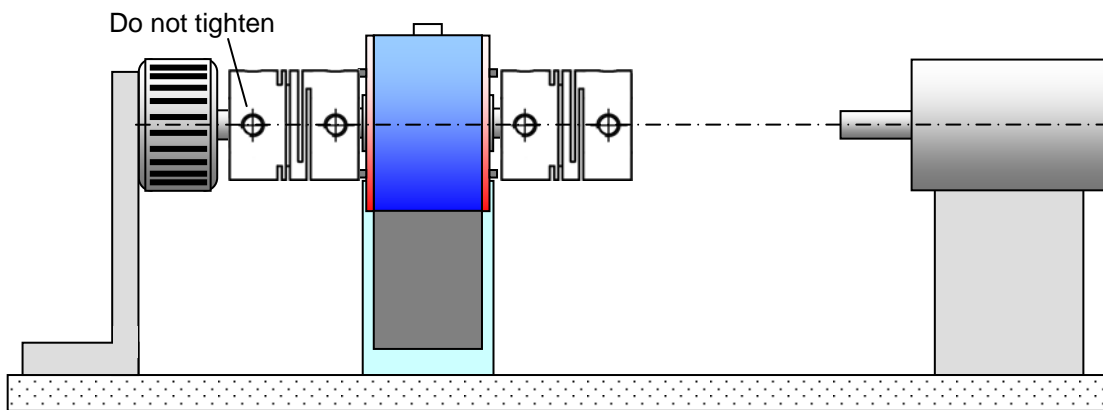

4. Carefully insert the second shaft string in the coupling without loading the housing or the shaft.

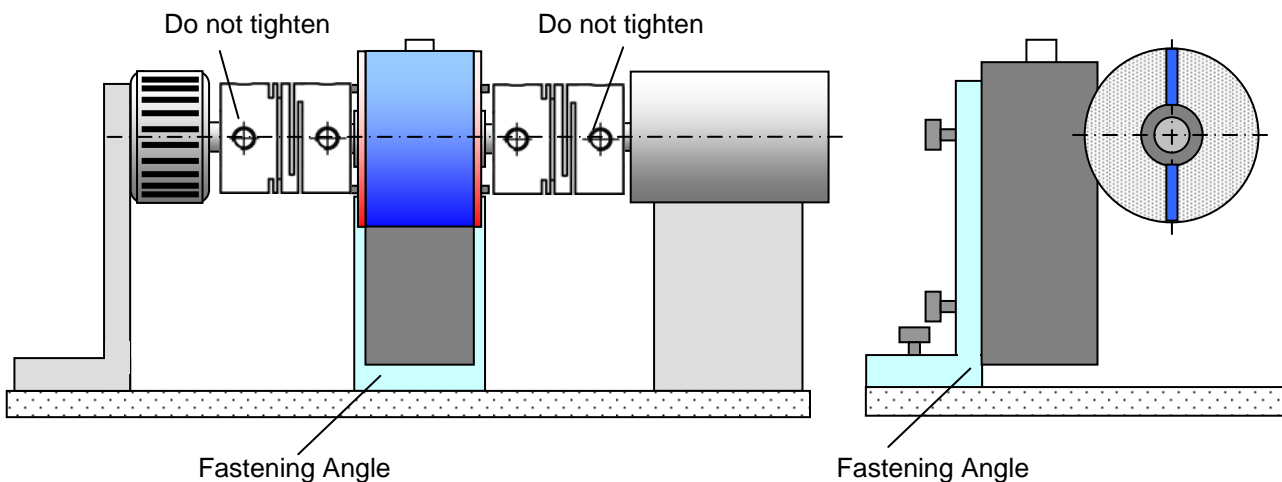

5. Align and slightly fasten the fastening part supplied by the customer (e.g. fastening angle) at the housing of the sensor.

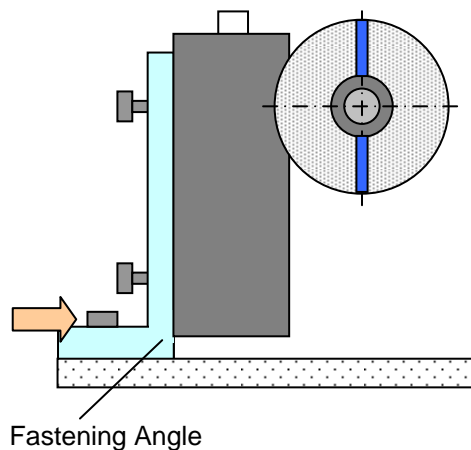

6. Slightly fasten the housing to the fastening part supplied by the customer (e.g. fastening angle) so that the position of the housing is fixed. The shaft may not be distorted by this.

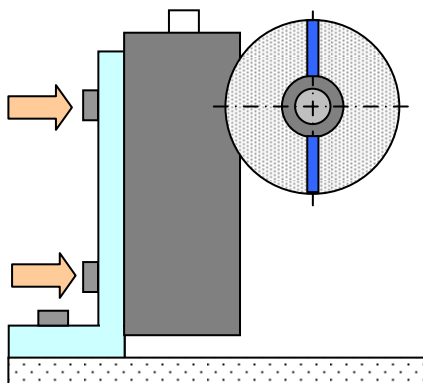

7. Remove fixing half shells.

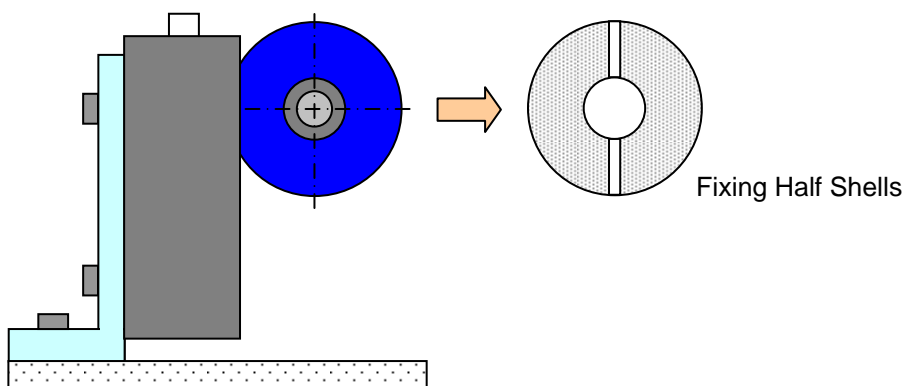

8. a) Firmly position angle support, then b) firmly position housing.

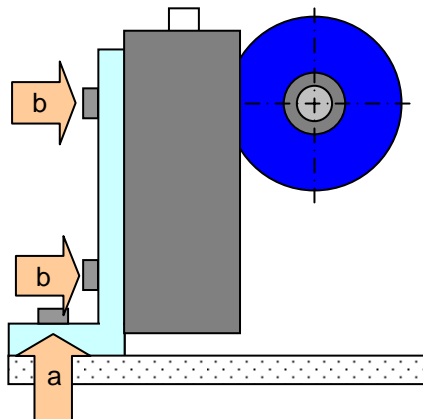

9. Fasten couplings on customers side, counterhold on coupling or at customers side. Start with the low torque resistance side (by this, no or just small torque will act on the shaft).

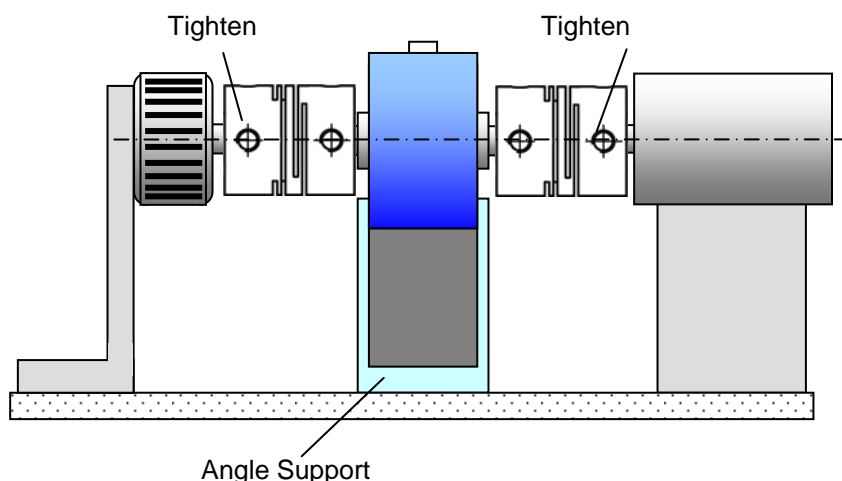

5 Electrical Connection

5.1 Pin Connection

See attached test certificate

8-pin	86-2500		86-2600	
1	Excitation +	12 ... 28 VDC	Excitation +	12 ... 28 VDC
2	Excitation GND	0 V	Excitation GND	0 V
3	Signal	$\pm 5 \text{ V} / (\pm 10 \text{ V})$	Output A	RS485
4	Signal GND	0 V	Output B	RS485
5	Control	$L < 2,0 \text{ V};$ $H > 3,5 \text{ V}$	NC	
6	Option Speed	TTL	Option Speed	TTL
7	NC		NC	
8	NC		NC	

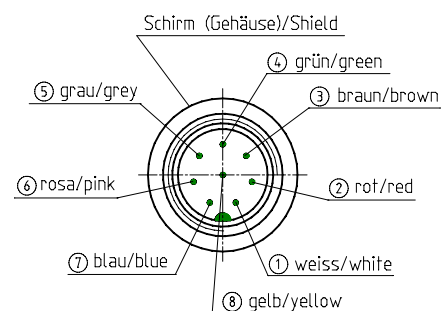

View: socket on soldering side

5.2 Cable

Only use a shielded cable with preferably small capacity. We recommend measuring cables from our product range. They have been tested in combination with our sensors and meet the metrological requirements.

5.3 Shielding Connection

In combination with the sensor and the external electronics, the shield forms a Faraday Cage. By this, electro-magnetic disturbances do not have any influence on the measurement signal.

5.4 Running of Measuring Cables

Do not run measuring cables together with control or heavy-current cables. Always assure that a large distance is kept to engines, transformers and contactors, because their stray fields can lead to interferences of the measuring signals. If troubles occur through the measuring cable, we recommend to run the cable in a grounded steel conduit.

5.5 Electrical Calibration

Only use the calibration control when the torque sensor is unstressed.

5.5.1 Switch-On of Calibration Control at Analog Output

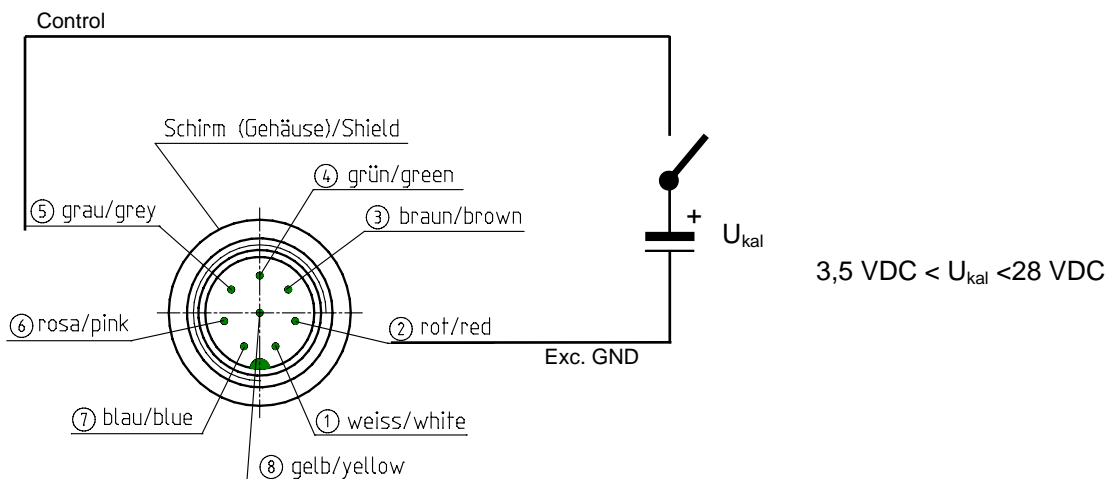

5.5.2 Calibration Control at RS485

The activation of the calibration control occurs through a command. For this see command SCMD_WriteFullStroke from Protocol (Document number 090110).

5.6 Speed Sensor (Option)

At the reflexion-procedure, the radiation of the light source is reflected differently from bright and dark surfaces, located on the shaft. Depending on the number of the markings at the shaft surface, a modulation of the light arises.

Optical samplings of the rotation speed are suitable for very small and also very large rotation speeds.

The sensor must be protected from pollution.

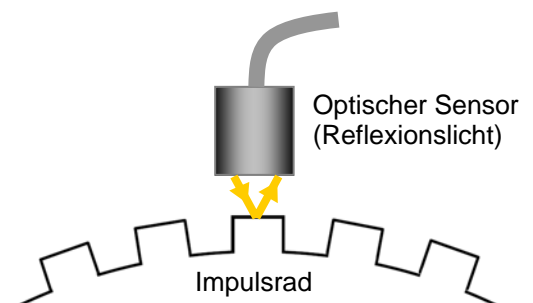

6 Measuring

6.1 Engaging

The warming-up period of the torque sensor is approx. 5 min. Afterwards the measurement can be started.



The warming-up period of the torque sensor is approx. 5 min.

6.2 Direction of Torque

Torque means clockwise or counter-clockwise torque if the torque acts clockwise when facing the shaft end. In this case a positive electrical signal is obtained at the output.

Torque sensors by burster can measure both, clockwise and counter-clockwise direction.

6.3 Static / Quasi-Static Torques

Static and/or quasi-static torque is a slowly changing torque.

The calibration of the sensors occurs statically on a calibration device.

The applied torque may accept any value up to the nominal torque.

6.4 Dynamic Torques

6.4.1 General

The static calibration procedure of torque sensors is also valid for dynamic applications.

Note: The frequency of torques must be smaller than the natural frequency of the mechanical measurement setup.

The band width of alternating torque must be limited to 70 % of the nominal torque.

6.4.2 Natural Resonances

Estimate of the mechanical natural frequencies:

$$f_0 = \frac{1}{2 \cdot \pi} \cdot \sqrt{c \cdot \left(\frac{1}{J_1} + \frac{1}{J_2} \right)}$$

f_0 = Natural Frequency in Hz
 J_1, J_2 = Moment of Inertia in $\text{kg} \cdot \text{m}^2$
 c = Torsional Rigidity in Nm/rad

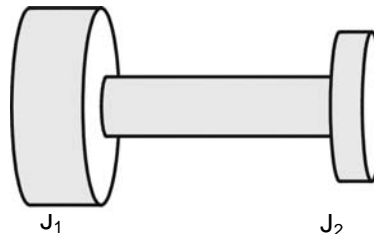

Further methods for the calculation of natural resonances are corresponding purchasable programs or books (e.g. Holzer-Procedure, Dubbel, Taschenbuch für den Maschinenbau, Springer Verlag)



Operation of the device in natural resonance can lead to permanent damages.

6.5 Speed Limits

The maximum speed indicated in the data sheet may not be exceeded in any operating state..

6.6 Disturbance Variables

By disturbances, measured value falsifications can occur by

- Vibrations,
- Temperature gradients,
- Temperature changes,
- Arising disturbance variables during operation, e.g. imbalance,
- Electrical disturbances,
- Magnetic disturbances,
- EMC (electromagnetic disturbances),

Therefore avoid these disturbance variables by decoupling of vibrations, covers, etc.

7 Maintenance

To a large extend, the torque sensor is maintenance-free

7.1 Maintenance Schedule

Action	Frequency	Date	Date	Date
Control of cables and connectors	1x p.a.			
Calibration	< 26 months			
Control of fixation (flanges, shafts)	1x p.a.			

7.2 Trouble Shooting

This chart is used for searching for the most frequent errors and their elimination

Problem	Possible Cause	Trouble Shooting
No signal	No sensor excitation	<ul style="list-style-type: none"> • Outside of permissible range • Connect excitation • Cable defect • No mains supply
	Signal output connected wrong	<ul style="list-style-type: none"> • Connect output correctly • Evaluation electronics defect
Sensor does not react to torque	Shaft not clamped	<ul style="list-style-type: none"> • Clamp correctly
	No power supply	<ul style="list-style-type: none"> • Outside of permissible range • Connect supply • Cable defect • No mains supply
	Cable defect	<ul style="list-style-type: none"> • Repair cable
	Connector connected wrong	<ul style="list-style-type: none"> • Connect correctly
Signal has dropouts	Axial position rotor to stator outside of tolerance	<ul style="list-style-type: none"> • Align rotor
	Cable defect	<ul style="list-style-type: none"> • Repair cable
Zero point outside of tolerance	Cable defect	<ul style="list-style-type: none"> • Repair cable
	Shaft mounted distorted	<ul style="list-style-type: none"> • Mount correctly
	Distorted shaft string	<ul style="list-style-type: none"> • Release from distortion
	Strong lateral forces	<ul style="list-style-type: none"> • Reduce lateral forces
	Distorted flanges	<ul style="list-style-type: none"> • Check evenness of flange-surfaces
	Shaft overloaded	<ul style="list-style-type: none"> • Send to manufacturer
Wrong torque indication	Calibration not correct	<ul style="list-style-type: none"> • Re-calibrate
	Sensor defect	<ul style="list-style-type: none"> • Repair by manufacturer
	Torque shunt	<ul style="list-style-type: none"> • Eliminate shunt
Shaft drags	Shaft drags in the rotor	<ul style="list-style-type: none"> • Align shaft • Concentricity of the parts is not ensured
	Lateral forces too large	<ul style="list-style-type: none"> • Decrease lateral forces
Oscillations	Alignment of shaft not correct	<ul style="list-style-type: none"> • Align correctly
	Unbalance	<ul style="list-style-type: none"> • Balance the corresponding parts

8 Decommission

- All sensors must be dismantled professionally.
- The dismantling of the torque sensor occurs in contrariwise sequence as described in chapter **Installation Instruction**.
- Couplings may not be damaged.
- Do not strike sensor housings with tools.
- Do not apply bending moments on the sensor, e.g. through levers.
- The torque sensor must be supported to avoid falling down during the dismantling.

9 Transportation and Storage

Transport or store the sensor with mounted fixing half shells, only!

The transportation of the sensors must occur in suitable packing.

For smaller sensors, stable cartons which are well padded are sufficient (e.g., air cushion film, epoxy crisps, paper shavings). The sensor should be tidily packed into film so that no packing material can reach into the sensor (ball bearings). Larger sensors should be packed in cases.

9.1 Transportation

Only release well packed sensors for transportation. The sensor should not be able to move back and forth in the packing. The sensors must be protected from moisture.

Only use suitable means of transportation.

9.2 Storage

The storage of the sensors must occur in dry, dust-free rooms, only.

Slightly lubricate shafts and flanges with oil before storing (rust).

10 Disposal

The torque sensors must be disposed according to the valid provisions of law.

For this, see our "General Terms and Conditions" www.burster.it

11 Calibration

At the time of delivery, torque sensors have been adjusted and tested with traceable calibrated measuring equipment at factory side. Optionally, a calibration of the sensors can be carried out.

11.1 Proprietary Calibration

Acquisition of measurement points and issuing of a calibration protocol Traceable calibrated measuring equipment is being used for the calibration. The sensor data are being checked during this calibration.

11.2 DKD-Calibration

The calibration of the sensor is carried out according to the guidelines of the DKD. The surveillance of the calibrating-laboratory takes place by the DKD. At this calibration, the uncertainty of measurement of the torque measuring instrument is determined. Further information can be obtained from burster.

11.3 Re-Calibration

The recalibration of the torque sensor should be carried out after 26 months at the latest.

Shorter intervals are appropriate:

- Overload of the sensor
- After repair
- After inappropriate handling
- Demand of high-quality standards
- Special traceability requirements

Apparecchi di misura di precisione. Sensori e Sistemi
per grandezze elettriche, termiche e meccaniche



12 Data Sheet

See www.burster.it